



SWS- 100 Weather Sensor

Monitors roadside weather to identify fog, haze, rain, drizzle and snow

... integrate into ITS controls and / or switch warnings automatically

- measurement range < 10 m - 2 km (1.2 miles)
- instantaneous and averaged visibility outputs
- identifies precipitation type
- reports WMO 4680 codes
- date and time stamp on data strings
- 2 relays to switch equipment and 1 fault relay
- easily installed on roadside posts or other structures

The SWS-100 model is designed primarily for use on roads, motorways and in tunnels to identify and warn of fog, haze, rain, drizzle, snow or other reductions to visibility.

The choice of digital (serial) and analogue outputs provides the flexibility to connect to a wide range of ITS (Intelligent Transport Systems) or other data controllers.

The unique ability to switch equipment using a fog relay and / or a precipitation relay is a feature of the SWS series. For example you can set the relays to automatically switch a speed reduction sign when the visibility is below

100 m and then switch an additional 'danger of aquaplaning' alert when it rains.

This is a quality sensor at an affordable price (less expensive than competitive sensors) with a remote monitoring and self test system to keep maintenance call outs to a minimum. Therefore, the savings realised from installing and running a network of SWS-100s can be substantial.

The SWS is lightweight, portable and easily pole mounted (for UK road use ask about our optional Post Adaptor to mount the sensor to Highways Agency posts).

SWS sensors use the same technology as the high specification HSS range of visibility and present weather sensors which have been in demand world-wide for over 20 years.

SWS- 100 Specifications

Visibility and precipitation measurements

measurement range	< 10 m - 2 km (1.2 miles) in 10 m increments
measures	visibility (MOR - Meteorological Optical Range) reductions caused by : fog, haze, smoke, sand, drizzle, rain, snow and general precipitation
measurement accuracy	<=10% maximum
measurement principle	forward scatter meter with 45 ° angle

Outputs and reports

output rate (seconds)	10 to 300 (selectable)
digital (serial) outputs	RS-232, RS-422, RS-485*
analogue outputs	0-10 V (4-20 mA or 0-20 mA optional)
switching relays <i>(providing flexible configurations)</i>	Relay 1 = fault Relay 2 = visibility (user selectable threshold) Relay 3 = precipitation yes/no or snow yes/no or 2nd visibility (user selectable)
outputs	selected WMO 4680 table codes

* single sensor connection only, not multi-drop

Power requirements

power supply	9-36 VDC (AC with optional mains adaptor)
power consumption	6 W - in normal running (no-dew window heaters ON) 2.5 W - with no-dew window heaters OFF 40 W - using optional de-icing hood heaters at 34 W

Options

de-icing hood heaters	in addition to the standard no-dew window heaters
analogue outputs	4-20 mA or 0-20 mA in addition to the 0-10 V output
extra self test mode	transmitter window contamination monitoring capability

Specifications subject to change E. & O. E.

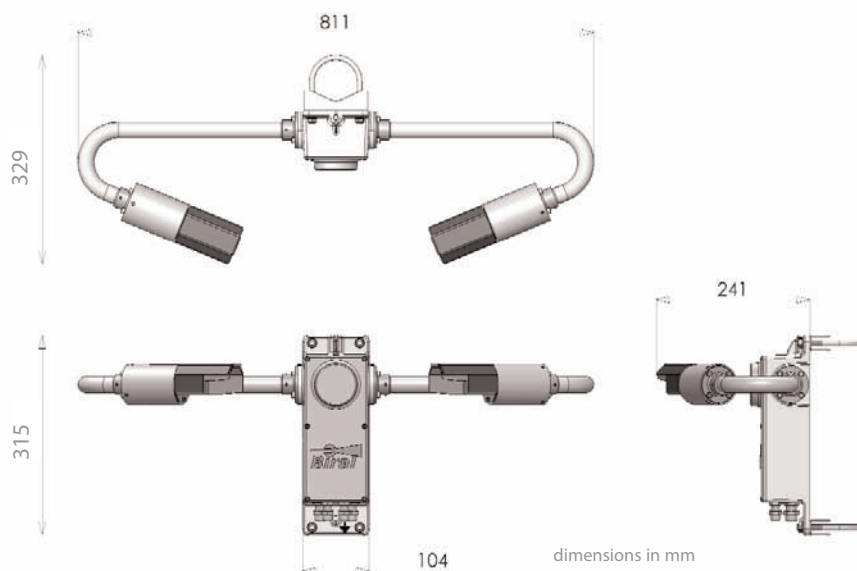

Environmental

operating temperature	-30 °C to +50 °C
operating humidity	0 - 100% RH
protection rating	IP65

CE certified

EMC compliance with EN61326-1997, 1998, 2001

RoHS and WEEE compliant

Physical

material	powder coated aluminium
weight	3.3 kg
length	0.81 m
lifetime	> 10 years

Maintenance

self test functions	with maintenance warnings
user confidence check	6 months (suggested)
window cleaning	3 months (suggested)

Included with the sensor

the SWS sensor is delivered in sturdy, recyclable foam-filled packaging with:

- 3 m RS232 auxiliary cable
- pole mounting kit (U bolt, saddle and bolts)
- documentation (manual, calibration certificate)

Accessories

power and data cables
mains power adaptor
calibration kit (for user confidence checks)
hard shell transit case (useful if the sensor is to be moved frequently)
post adaptor (for mounting to HA posts)